



Aménageur d'Espaces...

www.mbs95.com

15, rue de la Briqueterie 95330 DOMONT
Tél. 01 39 35 41 80 Fax 01 39 35 41 76 commercial@mbs95.com

m g r

sile . jet . jet evo
loopy . glider . take-off

 **bralco**
the next office

Index



Sile

p. 05-26



Jet

p. 27-46



Jet Evo

p. 47-68



Loopy



Glider

p. 69-94



Take-Off



accessori per elettrificazione · accessories for electification ·
accessoires pour électrification · Zubehör für Elektrifizierung ·
accesorios para electrificación

p. 95

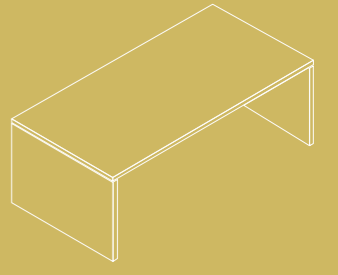

SILE

design:
Gianantonio Perin
Monica Fernandes

**Sile arreda gli spazi manageriali con eleganza,
prestigio e design contemporaneo.**

Sile furnishes managerial spaces with elegance,
prestige and contemporary design.

Sile meuble les espaces de direction avec élégance,
prestige et un design contemporain.

Sile richtet Chefräume mit Eleganz ein mit Prestige
und zeitgenössischem Design.

Sile amuebla espacios gerenciales con elegancia,
prestigio y diseño contemporáneo.

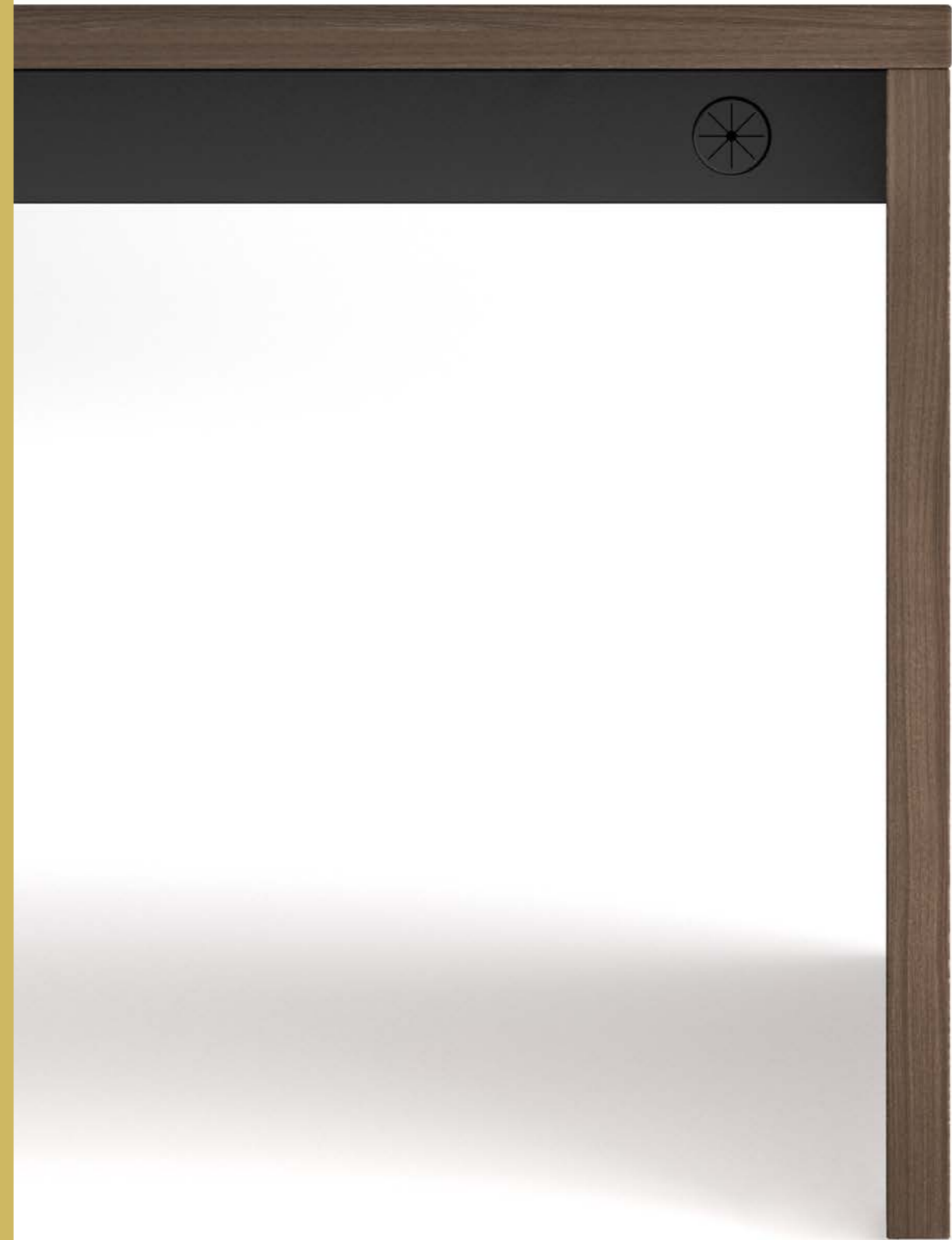





Il vano frontale del mobile di servizio portante, disponibile in varie finiture, anche colorato, dona leggerezza e dinamicità a Sile!

The front compartment of the load-bearing service cabinet, available in various finishes, also colored, gives Sile lightness and dynamism!

Le compartiment en avant et ouvert du meuble de service, disponible en différentes finitions et couleurs, donne à Sile légèreté et dynamisme !

Das Frontfach des Stand-Technickcontainer, erhältlich in verschiedenen Ausführungen, auch farbig, verleiht Sile Leichtigkeit und Dynamik!

El compartimento frontal del armario de servicio portante, disponible en varios acabados, también coloreados, aporta ligereza y dinamismo a Sile!







Disponibile anche il dattilo laterale regolabile in altezza elettricamente; per un modo contemporaneo ed ergonomico di lavorare.

The electrically height-adjustable side return is also available; for a contemporary and ergonomic way of working.

Le retour avec réglage électrique en hauteur est également disponible, pour un poste de travail contemporain et ergonomique.

Der elektrisch höhenverstellbare Ansatz Tisch ist ebenfalls erhältlich; für eine zeitgemäße und ergonomische Arbeitsweise.

También está disponible el ala lateral regulable eléctricamente en altura; para una forma contemporánea y ergonómica de trabajar.











melaminico, melamine, mélamine,
melamin, melamina



laccato opaco, lacquered matt, lacqué mat
matt lackiert, lacado mate

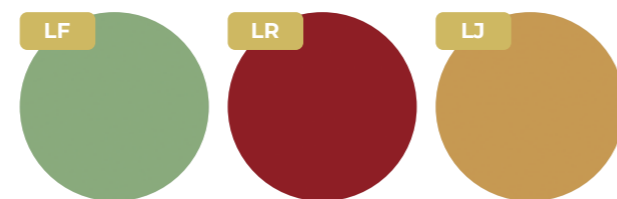
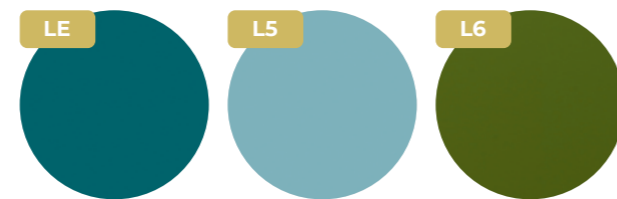
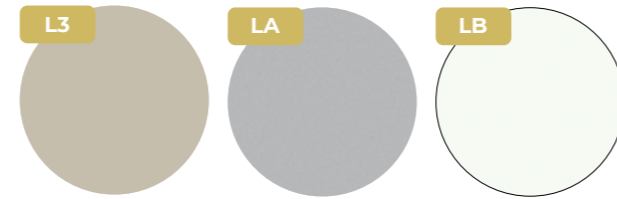
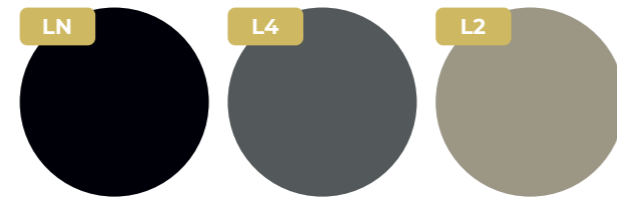

vetro temperato, tempered glass, verre trempé,
sicherheitsglas, vidrio templado

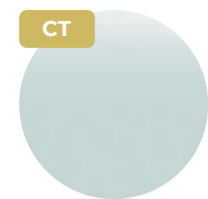

vetro temperato retrolaccato, back-lacquered tempered glass, verre retro-lacqué trempé,
sicherheitsglas rückseitig lackiert, vidrio retrolacado templado

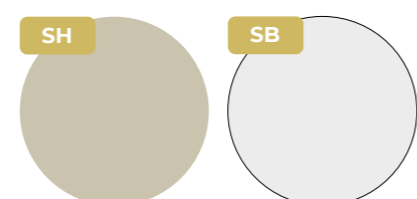
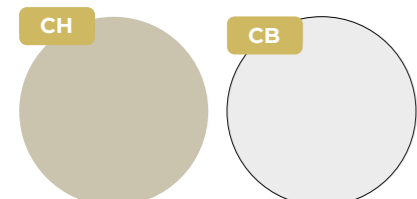
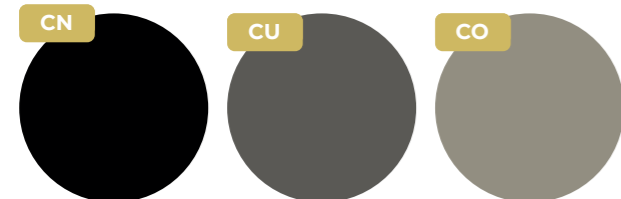

C_ (lucido · glossy · brillant · poliert · brillo)

S_ (opaco · matt · opaque · matt · mate)

pelle, leather, cuir,
Leder, piel



pelle ecologica, eco-leather, peau écologique,
Kunstleder, eco-piel

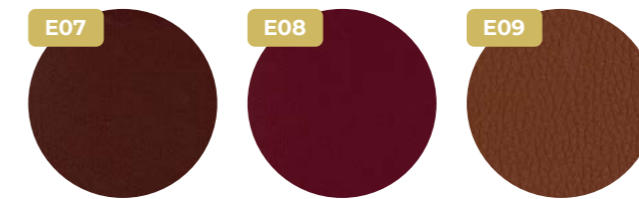
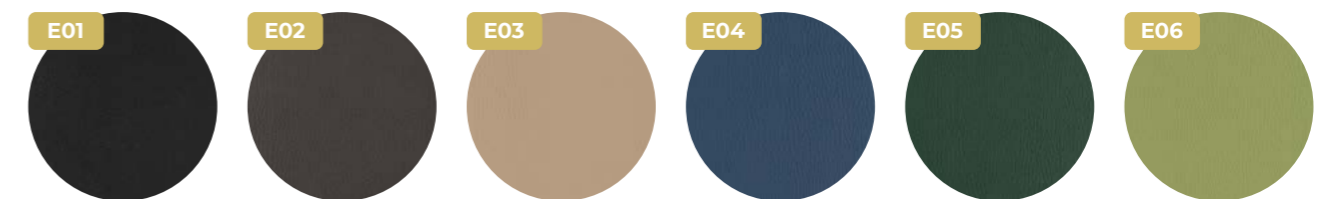

dettaglio cucitura inserto in pelle, leather insert seam detail, détail de couture d'insertion de cuir,
Nahtdetail mit Ledereinsatz, detalle de costura de inserción de cuero



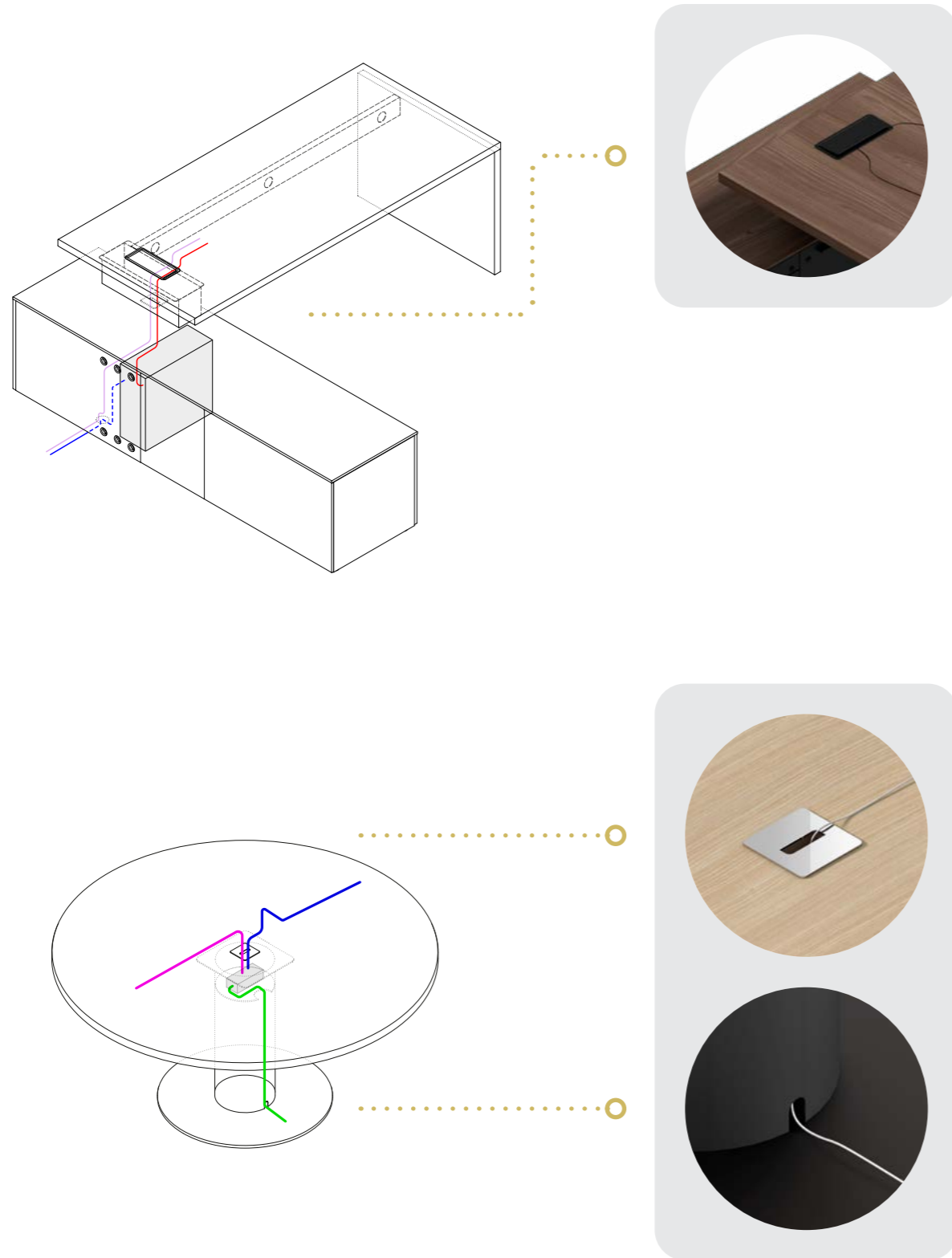

h 74 cm

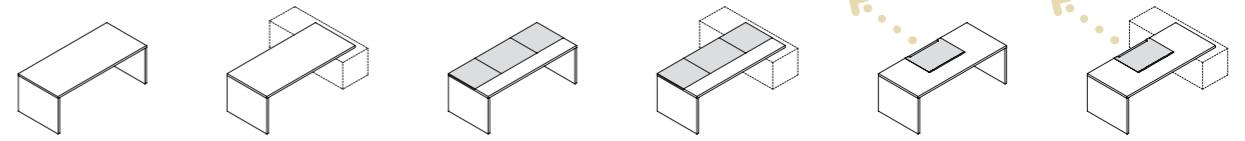

w 180-200 cm
d 90 cm

h 74 cm

h 67÷132 cm

h 30 cm

h 40 cm

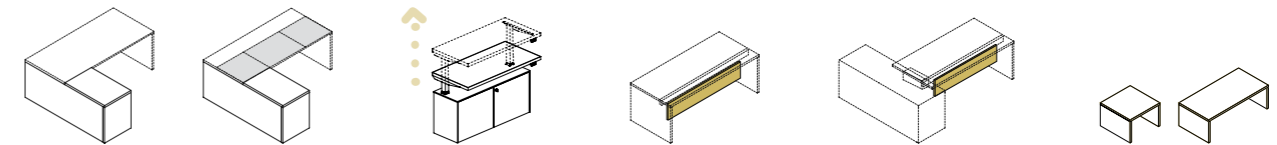

w 180-200 cm
d 180 cm

w 122,5 cm
d 60 cm

w 120÷160 cm
d 1,8 cm

w 60-120 cm
d 60 cm

h 54 cm

h 58,5 cm

h 54 cm

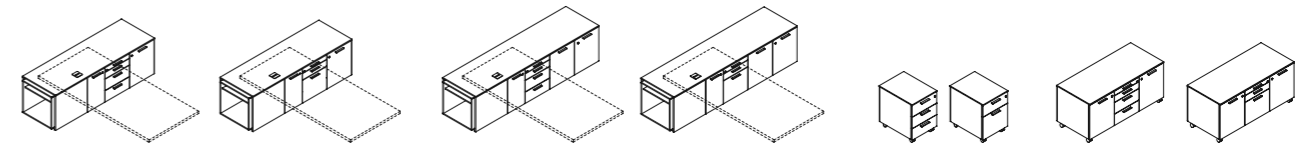

w 170,2 cm
d 56,2 cm

w 211,9 cm
d 56,2 cm

w 41,7 cm
d 56,2 cm

w 125,3 cm
d 56,2 cm

h 73,7 cm

h 124,9 cm

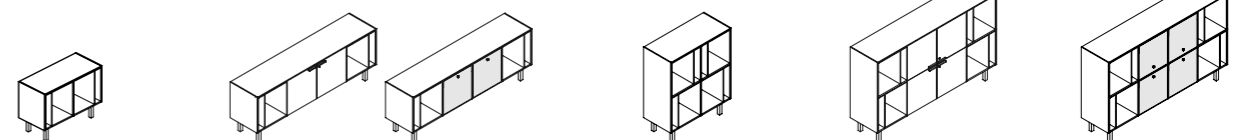

w 102,4 cm
d 46 cm

w 202,4 cm
d 46 cm

w 102,4 cm
d 46 cm

w 202,4 cm
d 46 cm



h 74 cm

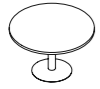

ø 120 cm

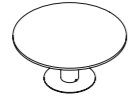

ø 140-160 cm

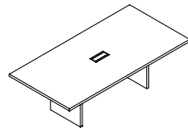

w 240 cm
d 120 cm

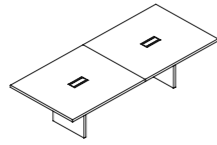

w 280 cm
d 120 cm

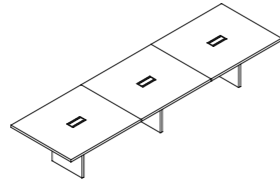

w 420 cm
d 120 cm



w 240 cm
d 120 cm

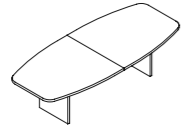

w 280 cm
d 120 cm

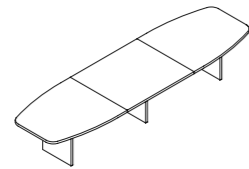

w 420 cm
d 120 cm

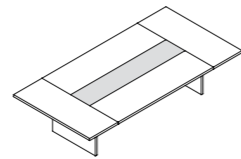

w 320 cm
d 160 cm

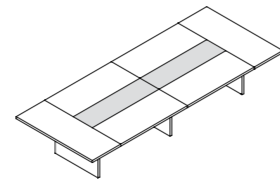

w 400-480 cm
d 160 cm



h 78,6 - 117 - 155,4 - 193,8 cm

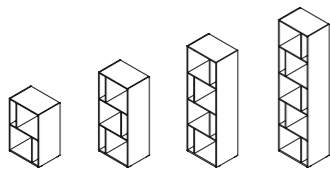

w 50 cm
d 36,3 cm

h 76,8 - 115,2 - 153,6 - 192 cm

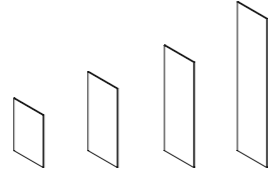

w 50 cm
d 1,2 cm

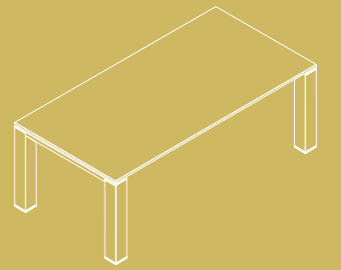

JET®

design:
Perin & Topan



**Sistema manageriale dal forte carattere e molteplicità di configurazioni e varianti:
due diverse strutture e varie tipologie di piani per personalizzare ogni progetto.**

Managerial system with a strong character and multiplicity of configurations and variants:
two different structures and various types of tops to customize each project.

Système managérial à fort caractère et multiplicité de configurations et de variantes :
deux structures différentes et plusieurs types de plateaux pour personnaliser chaque projet.

Chefzimmer mit starkem Charakter und einer Vielzahl von Konfigurationen und Varianten:
zwei verschiedene gestellen und verschiedene Arten von tischplatten,
um jedes Projekt individuell zu gestalten.

Sistema de dirección con carácter fuerte y multiplicidad de configuraciones y variantes:
dos estructuras diferentes y varios tipos de tapas para personalizar cada proyecto.

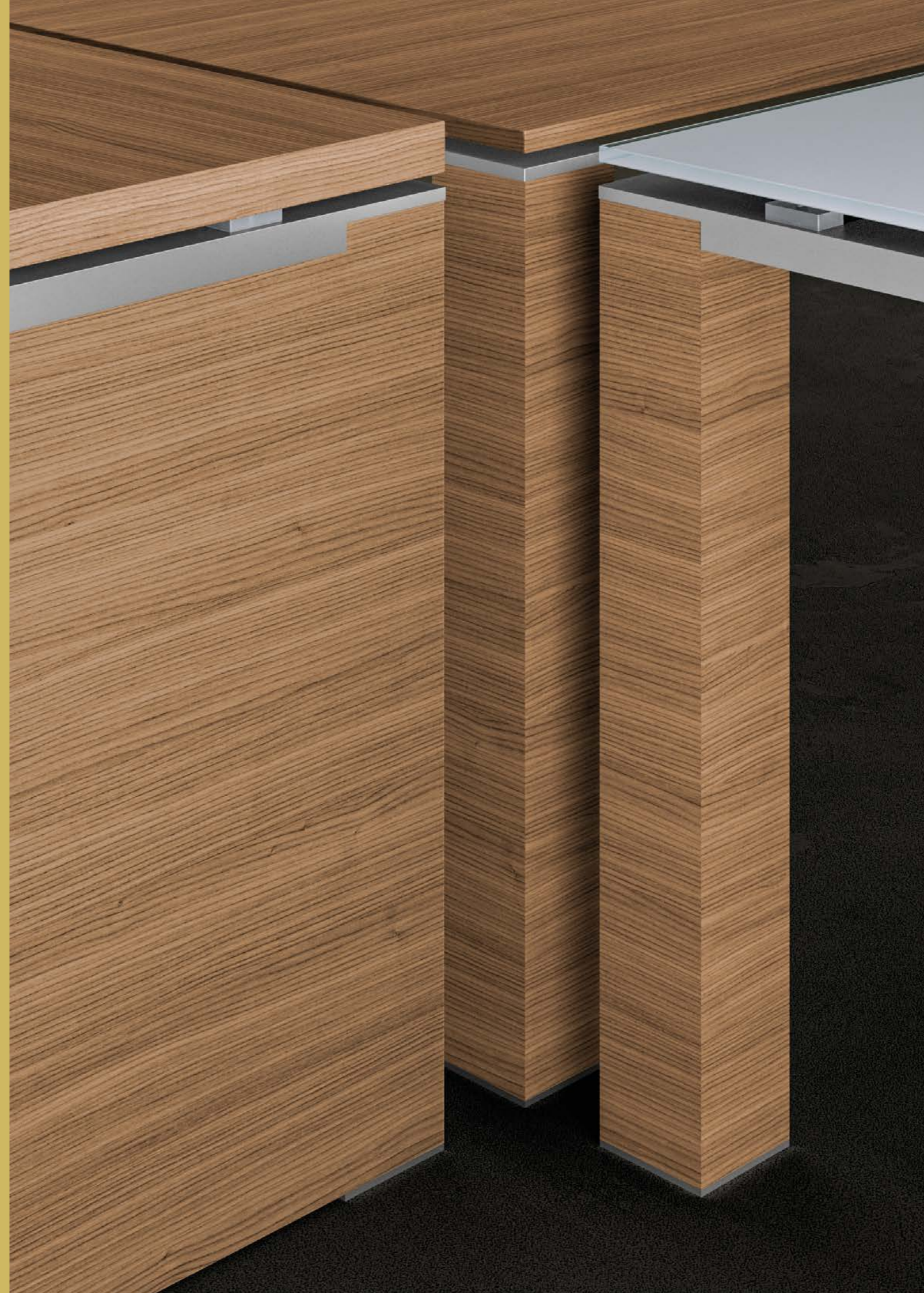







Diverse soluzioni funzionali e due tipologie di struttura permettono di arredare l'ufficio manageriale a misura d'uomo.

Different functional solutions and two types of structure allow you to furnish the managerial office on a human scale.

Différentes solutions fonctionnelles et deux types de structure permettent de meubler le bureau de direction à taille humaine.

Verschiedene funktionale Lösungen und zwei Arten von gestellen ermöglichen es Ihnen, das Chefsbüro in menschlicher Größe einzurichten.

Diferentes soluciones funcionales y dos tipos de estructura le permiten amueblar la oficina de dirección a escala humana.







Tavoli riunione che rispondono a molteplici necessità grazie alle numerose combinazioni e dimensioni dei piani.

Meeting tables covering multiple needs thanks to the several combinations and sizes of the tops.

Des tables de réunion qui répondent à de multiples besoins grâce aux nombreuses combinaisons et dimensions des plateaux.

Besprechungstische, die dank der zahlreichen Kombinationen und Größen der Platten mehrere Anforderungen erfüllen.

Mesas de reunión que satisfacen múltiples necesidades gracias a las numerosas combinaciones y tamaños de las tapas.



Una vasta gamma di contenitori completa lo spazio con abbinamenti eleganti e coordinati.

A wide range of containers completes the space with elegant and coordinated combinations.

Une large gamme de conteneurs complète l'espace avec des combinaisons élégantes et coordonnées.

Eine große Auswahl an Container vervollständigt den Raum mit eleganten und aufeinander abgestimmten Kombinationen.

Una amplia gama de contenedores completa el espacio con combinaciones elegantes y coordinadas.





melaminico, melamine, mélamine,
melamin, melamina



laccato opaco, lacquered matt, lacqué mat
matt lackiert, lacado mate

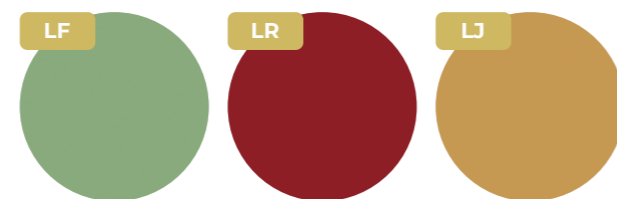
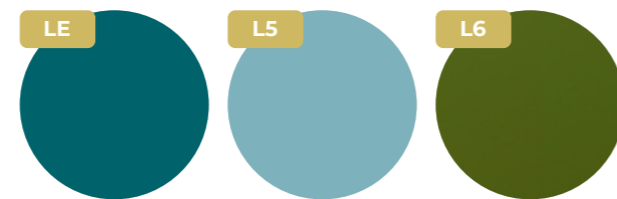
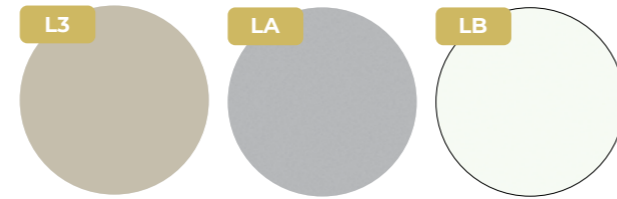
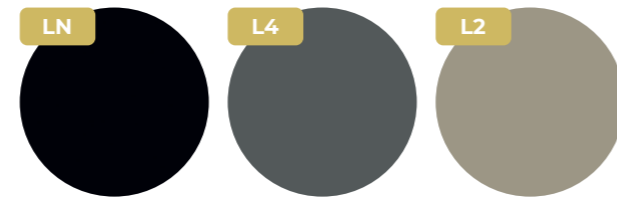

vetro temperato, tempered glass, verre trempé,
sicherheitsglas, vidrio templado

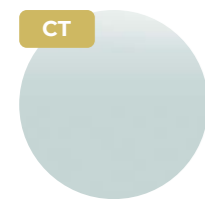

vetro temperato retrolaccato, back-lacquered tempered glass, verre retro-lacqué trempé,
sicherheitsglas rückseitig lackiert, vidrio retrolacado templado

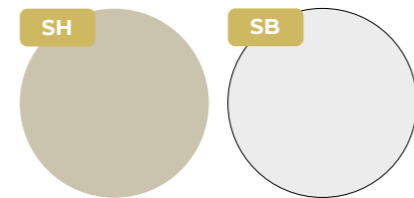
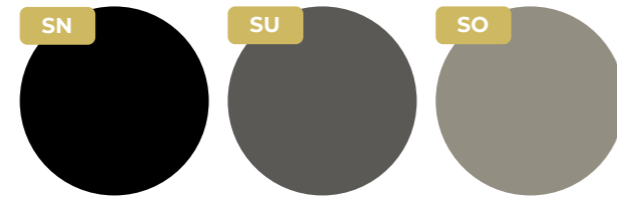
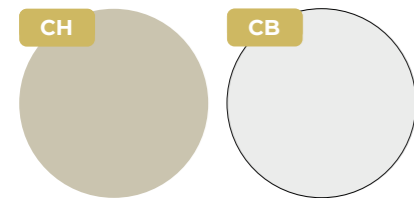
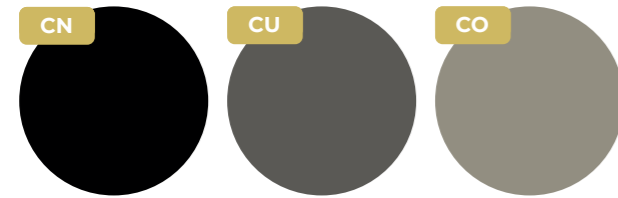

C_ (lucido · glossy · brillant · poliert · brillo)

S_ (opaco · matt · opaque · matt · mate)

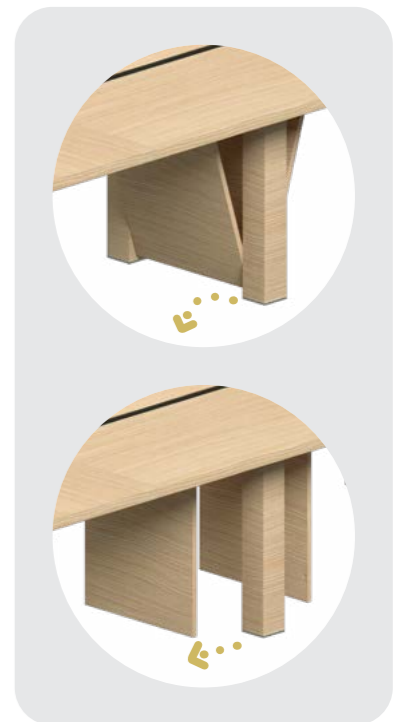
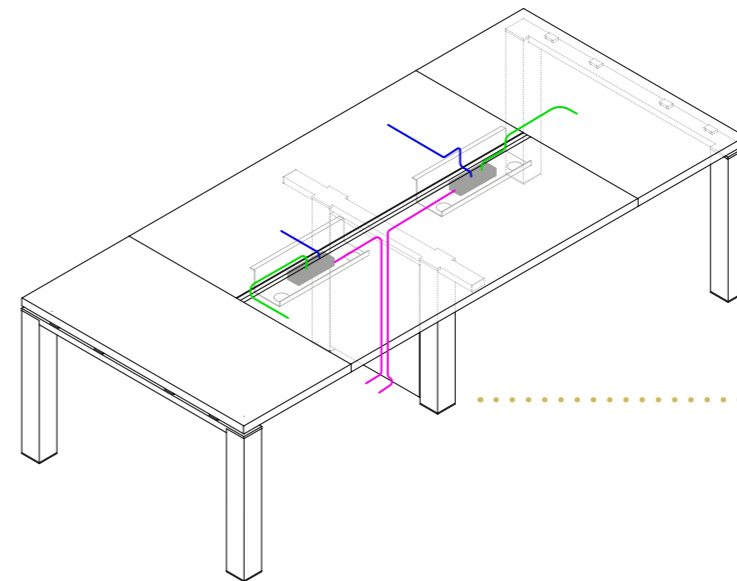
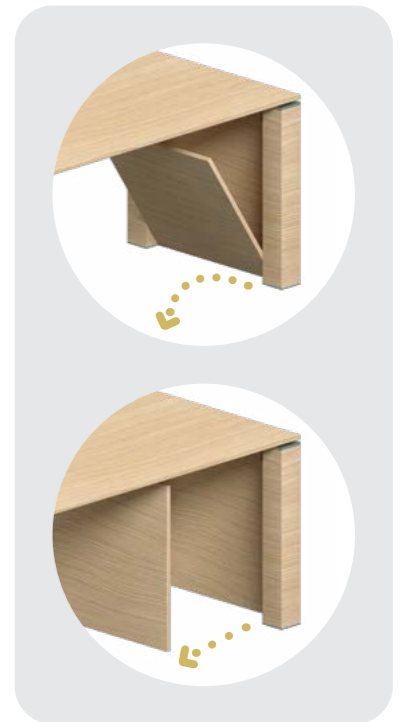
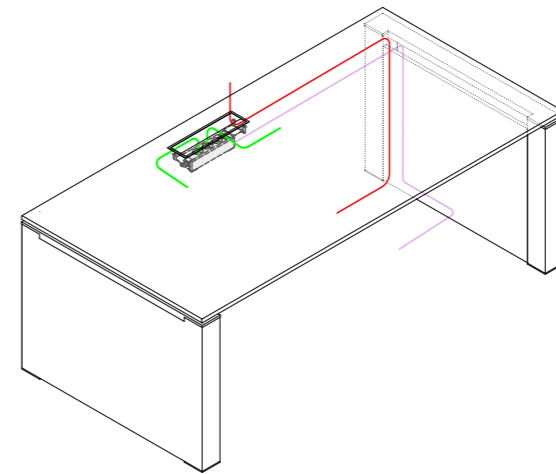



h 74 cm

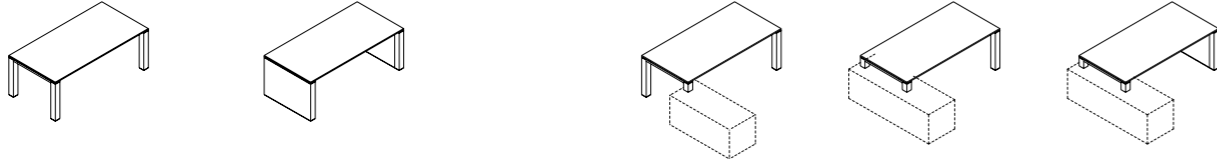

w 80÷200 cm
d 60 cm

w 160÷200 cm
d 80 cm

w 180÷200 cm
d 100 cm

w 160÷200 cm
d 80 cm

w 180÷200 cm
d 100 cm

s 1,2-1,8-3,8 cm

h 74 cm

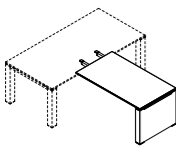

w 140 cm
d 80 cm

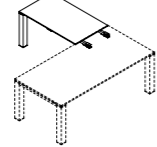
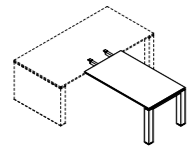

w 80÷120 cm
d 60 cm

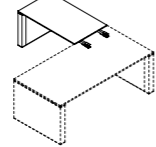

h 2 cm

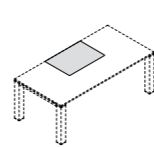

w 70 cm
d 50 cm

s 1,2-1,8-3,8 cm

h 30 cm

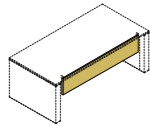

w 118,5-138,5-158,5 cm
d 1,8 cm

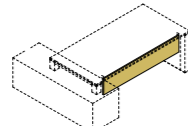

w 98,5-118,5-138,5 cm
d 1,8 cm

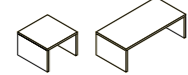

w 60-120 cm
d 60 cm

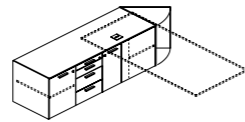

w 167,8 cm
d 56,2 cm

h 40 cm

h 54 cm

h 54 cm

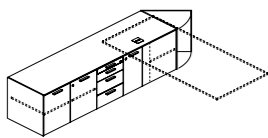

w 209,5 cm
d 56,2 cm

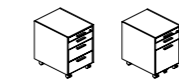
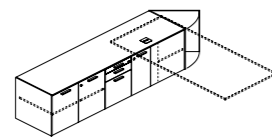

w 44,3 cm
d 56,2 cm

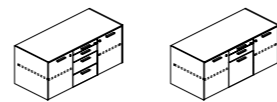

w 127,7 cm
d 56,2 cm

h 58,5 cm

h 54 cm



h 73,7 cm

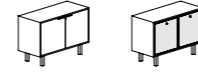

w 102,4 cm
d 46 cm

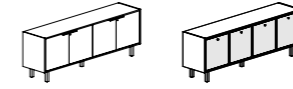

w 202,4 cm
d 46 cm

h 124,9 cm

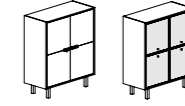

w 102,4 cm
d 46 cm

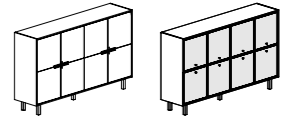

w 202,4 cm
d 46 cm

h 74 cm

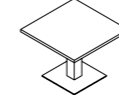

w 100 cm
d 100 cm

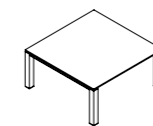

w 124 cm
d 124 cm

w 164 cm
d 164 cm

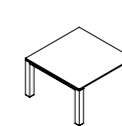

w 124 cm
d 124 cm

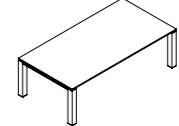

w 240 cm
d 124 cm

s 1,2-3,8 cm

s 1,8-3,8 cm

s 1,2-1,8-3,8 cm



h 74 cm

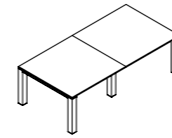

w 248 cm
d 124 cm

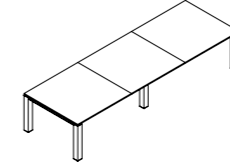

w 372 cm
d 124 cm

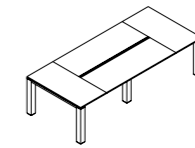

w 280-300-320 cm
d 124-164 cm

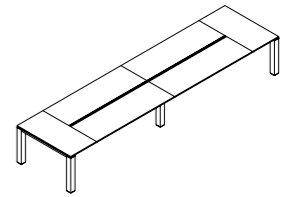

w 440-480 cm
d 124-164 cm

s 1,2-1,8-3,8 cm

s 1,8-3,8 cm



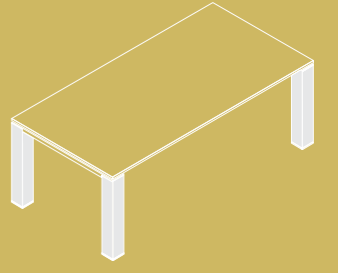

JET EVO

design:
Perin & Topan

**Finiture in acrilico lucido e dettagli cromati rendono chic la collezione Jet Evo.
Ambienti manageriali e sale riunioni dinamici e di immagine.**

Glossy acrylic finishes and chromed details make the Jet Evo collection chic.
Managerial environments and dynamic meeting rooms with an image.

Les finitions acryliques brillantes et les détails chromés rendent la collection Jet Evo chic.
Des environnements managériaux et des salles de réunion dynamiques et d' image.

Glänzende Acryl-Oberflächen und verchromte Details machen die Jet Evo-Kollektion schick.
Management-Umgebungen und dynamische Besprechungsräume mit Image.

Los acabados acrílicos brillantes y los detalles cromados dan elegancia a la colección Jet Evo.
Ambientes directivos y salas de reuniones dinámicas y con imagen.

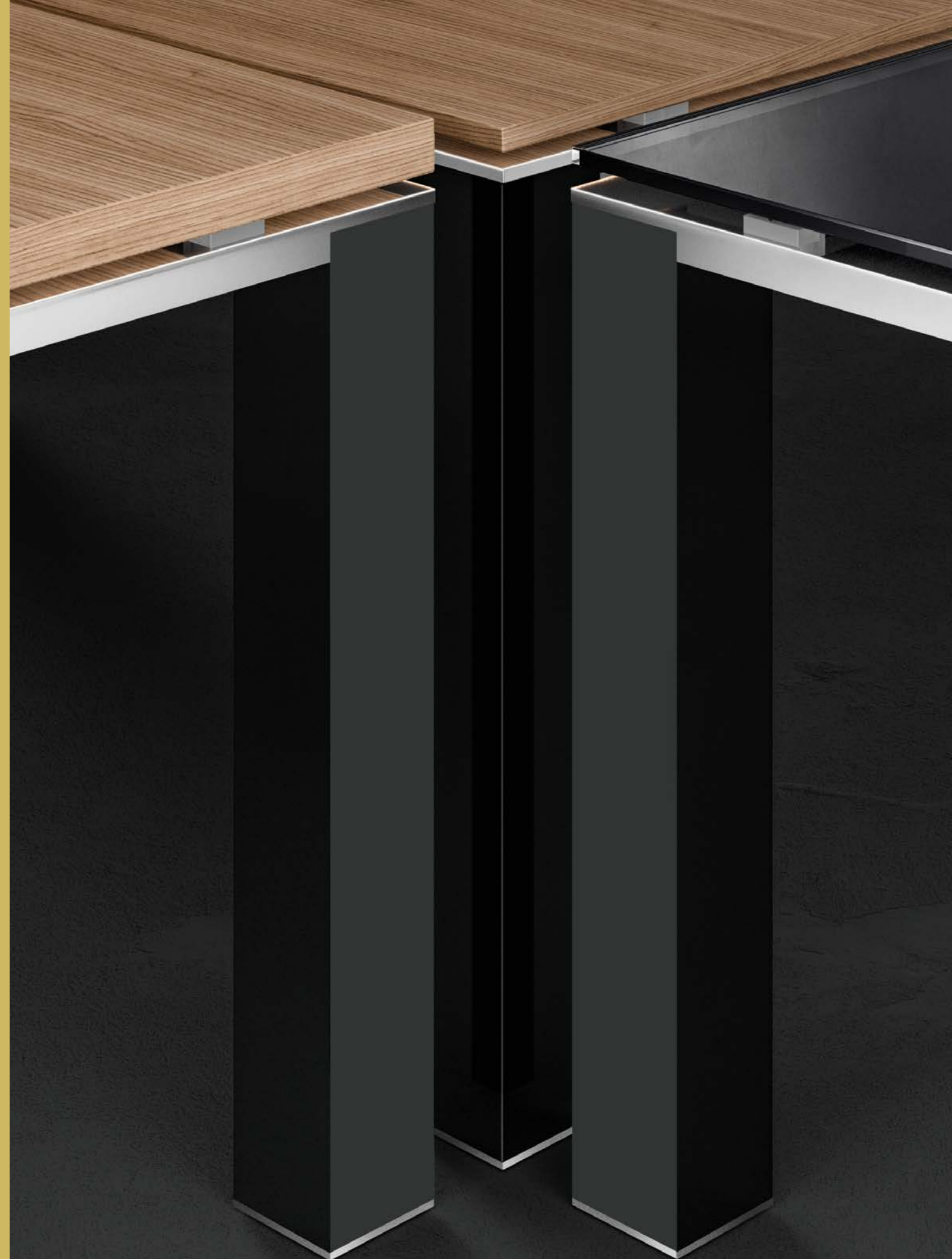





La ricchezza dell'acrilico lucido della struttura è presente anche nei contenitori per un risultato coordinato di prestigio.

The richness of the glossy acrylic of the structure is also present in the containers for a coordinated result of prestige.

La richesse de l'acrylique brillant de la structure est également présente dans les armoires pour un résultat coordonné et de prestige.

Der Reichtum des glänzenden Acryls der Struktur ist auch in den Behältern für ein koordiniertes Ergebnis von Prestige vorhanden.

La riqueza del acrílico brillante de la estructura también está presente en los contenedores para un resultado coordinado de realce.







Jet Evo propone soluzioni meeting ideali anche per gli uffici più contenuti con eleganza e prestigio.

Jet Evo offers ideal meeting solutions even for smaller offices with elegance and prestige.

Jet Evo offre des solutions de réunion idéales même pour les petits bureaux avec élégance et prestige.

Jet Evo bietet ideale Besprechungslösungen auch für kleinere Büros mit Eleganz und Prestige.

Jet Evo ofrece soluciones de reunión ideales incluso para oficinas más pequeñas con elegancia y prestigio.



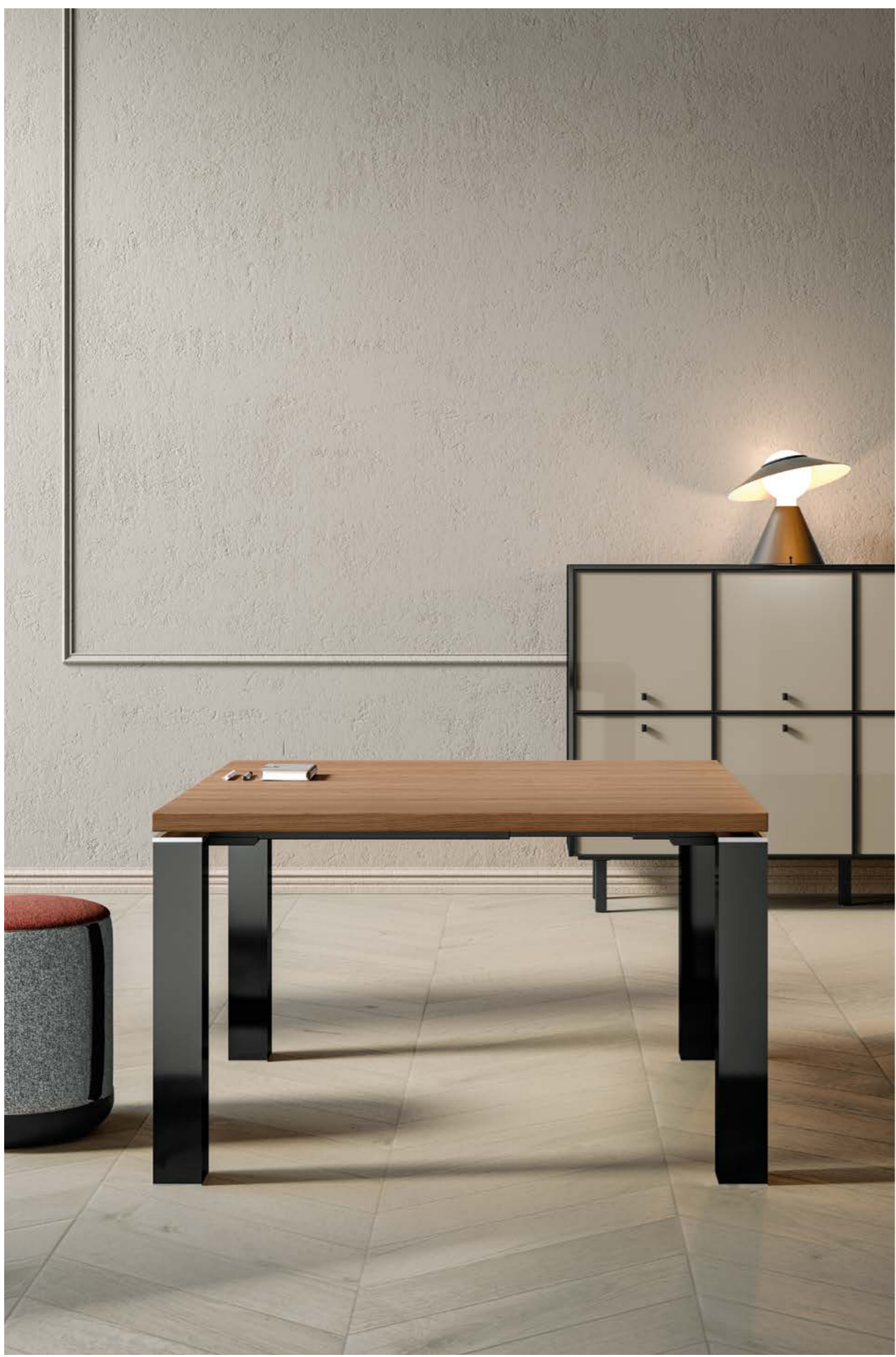





melaminico, melamine, mélamine,
melamin, melamina

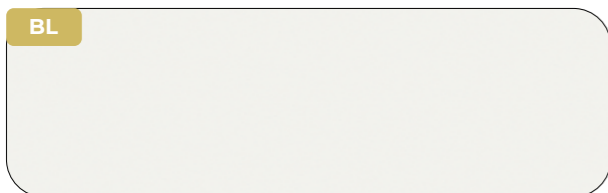

vetro temperato retrolaccato, back-lacquered tempered glass, verre retro-lacqué trempé,
sicherheitsglas rückseitig lackier, vidrio retrolacado templado

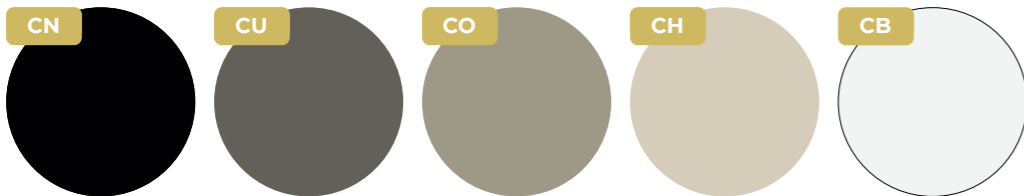

C_ (lucido · glossy · brillant · poliert · brillo)

acrilico lucido, glossy acrylic, acrylique brillant,
glänzende acryl, acrílico brillo



vetro temperato, tempered glass, verre trempé,
sicherheitsglas, vidrio templado

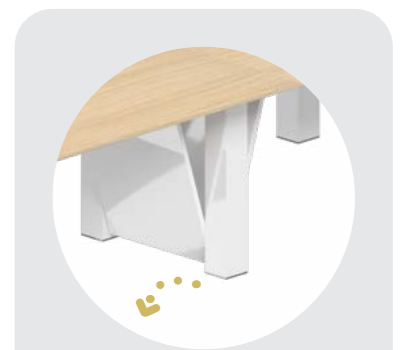
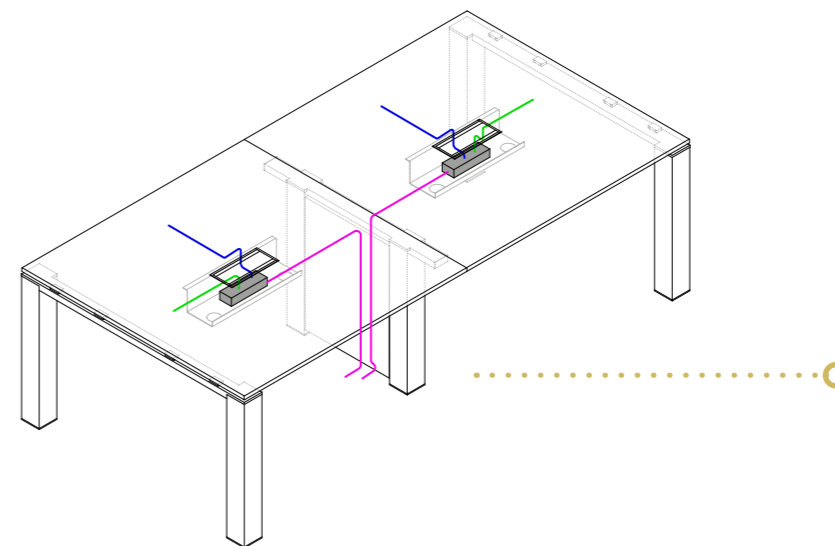
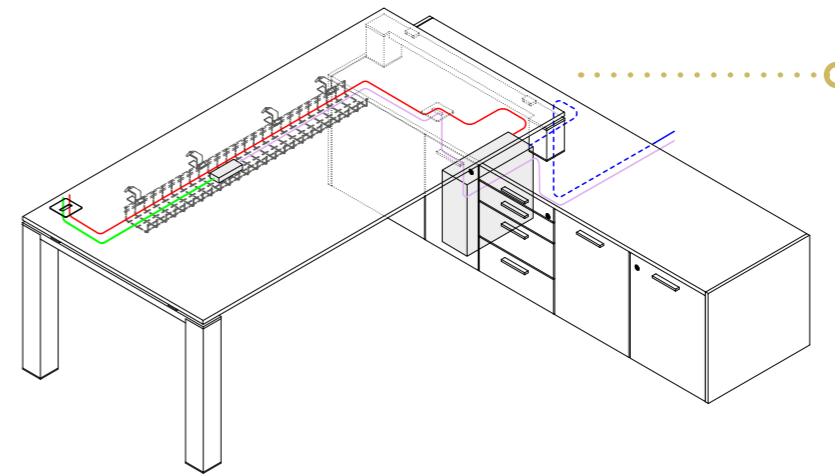



h 74 cm

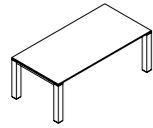

w 80÷200 cm
d 60 cm

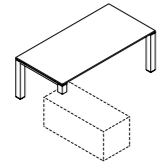

w 160÷200 cm
d 80 cm

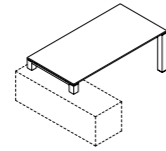

w 180÷200 cm
d 100 cm

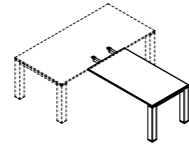

w 140 cm
d 80 cm

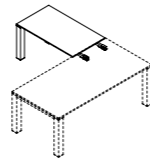

w 80÷120 cm
d 60 cm

s 1,2-1,8-3,8 cm

h 2 cm

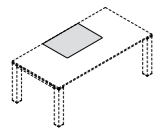

w 70 cm
d 50 cm

h 30 cm

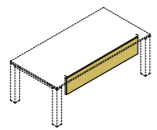

w 118,5-138,5-158,5 cm
d 1,8 cm

h 54 cm

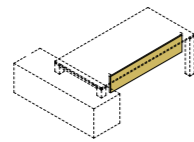

w 98,5-118,5-138,5 cm
d 1,8 cm

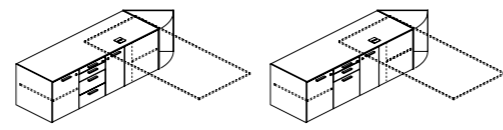

w 167,8 cm
d 56,2 cm

h 54 cm

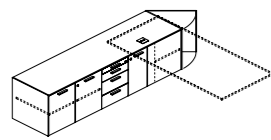

w 209,5 cm
d 56,2 cm

h 58,5 cm

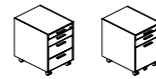

w 44,3 cm
d 56,2 cm

h 54 cm

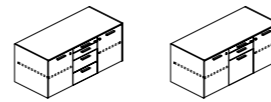

w 127,7 cm
d 56,2 cm

h 73,7 cm

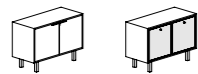

w 102,4 cm
d 46 cm

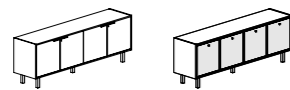

w 202,4 cm
d 46 cm

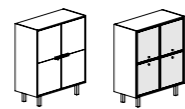

w 102,4 cm
d 46 cm

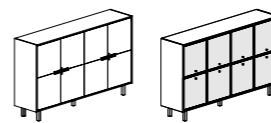

w 202,4 cm
d 46 cm



h 74 cm

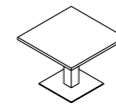

w 100 cm
d 100 cm

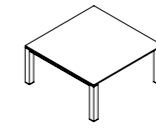

w 124 cm
d 124 cm

w 164 cm
d 164 cm

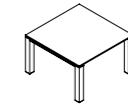

w 124 cm
d 124 cm

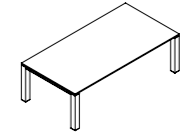

w 240 cm
d 124 cm

s 1,2-3,8 cm



s 1,8-3,8 cm



s 1,2-1,8-3,8 cm



h 74 cm

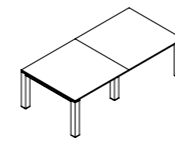

w 248 cm
d 124 cm

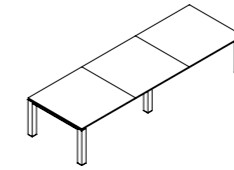

w 372 cm
d 124 cm

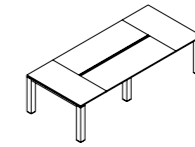

w 280-300-320 cm
d 124-164 cm

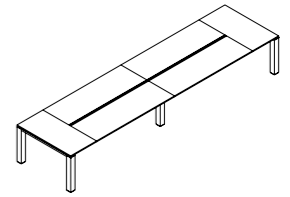

w 440-480 cm
d 124-164 cm

s 1,2-1,8-3,8 cm



s 1,8-3,8 cm



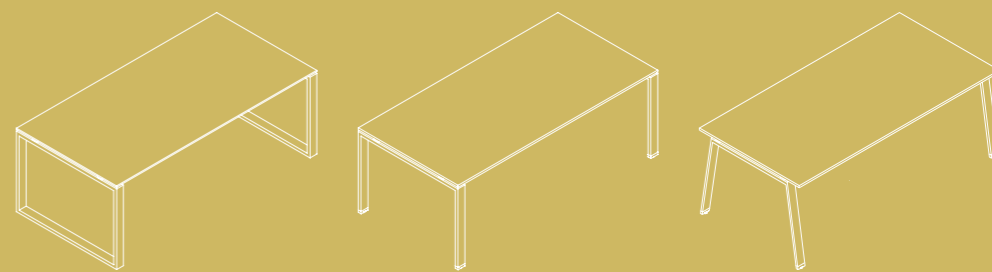

**LOOPY
GLIDER
TAKE-OFF**

design:
Perin & Topan

Un'ampia gamma di finiture e materiali caratterizza le linee manageriali di Loopy, Glider e Take-Off permettendo di arredare spazi direzionali e meeting contemporanei.

A wide range of finishes and materials characterize the managerial lines of Loopy, Glider and Take-Off allowing you to furnish executive and contemporary meeting spaces.

Une large gamme de finitions et de matériaux caractérise les lignes managériales de Loopy, Glider et Take-Off en vous permettant de meubler des espaces de réunion exécutifs et contemporains.

Eine große Auswahl an Oberflächen und Materialien charakterisieren die Managementlinien Loopy, Glider und Take-Off, mit denen Sie Executive- und moderne Besprechungsräume einrichten können.

Una amplia gama de acabados y materiales caracterizan las líneas gerenciales de Loopy, Glider y Take-Off que le permiten amueblar espacios de reunión ejecutivos y contemporáneos.

















Vasta scelta di forme e dimensioni: dal tavolo riunione compatto ai sistemi modulari per sale di grandi dimensioni.

Wide choice of shapes and sizes: from the compact meeting table to modular systems for large rooms.

Large choix de formes et de tailles : de la table de réunion compacte aux systèmes modulaires pour les grandes salles.

Große Auswahl an Formen und Größen: vom kompakten Besprechungstisch bis zum modularen System für große Räume.

Amplia variedad de formas y tamaños: desde la mesa de reunión compacta hasta los sistemas modulares para salas grandes.







Tavolini bassi coordinati per arredare le zone lounge.

Coordinated low tables to furnish lounge areas.

Tables basses coordonnées pour meubler les espaces lounge.

Koordinierte niedrige Tische zur Einrichtung von Loungebereichen.

Mesas bajas coordinadas para amueblar zonas lounge.



legno, veneer, bois,
Holz Furnier, madera

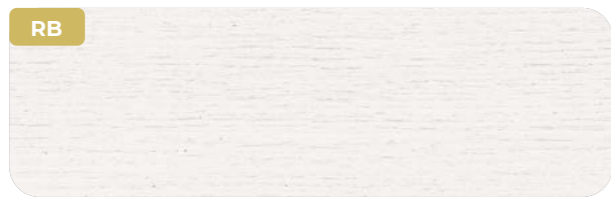

melaminico, melamine, mélamine,
melamin, melamina

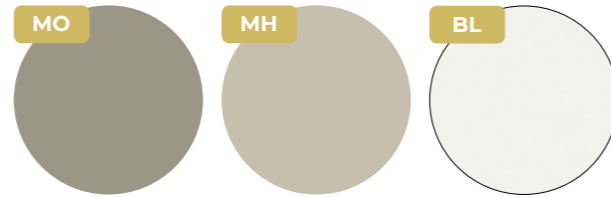

vetroceramica, ceramic glass, vitroceramique,
glaskeramik, vidrio cerámica



vetro temperato retrolaccato, back-lacquered tempered glass, verre retro-lacqué trempé,
sicherheitsglas rückseitig lackier, vidrio retrolacado templado



C_ (lucido · glossy · brillant · poliert · brillo)

S_ (opaco · matt · opaque · matt · mate)

vetro temperato, tempered glass, verre trempé,
sicherheitsglas, vidrio templado

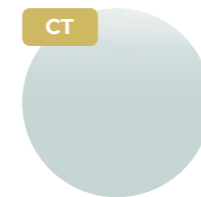

strutture metalliche, metal structures, structures métalliques,
metallgestelle, estructuras metálicas

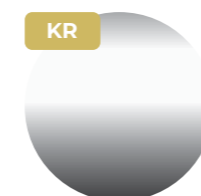
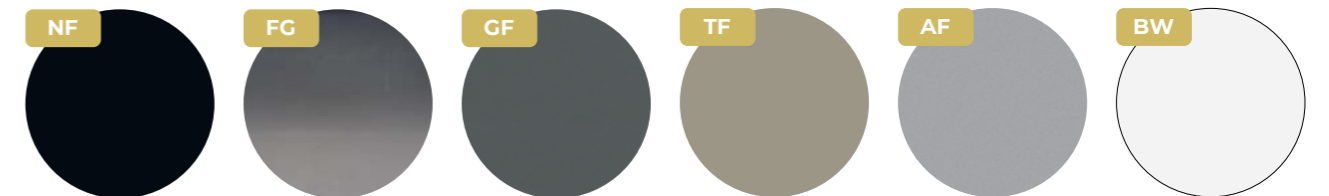

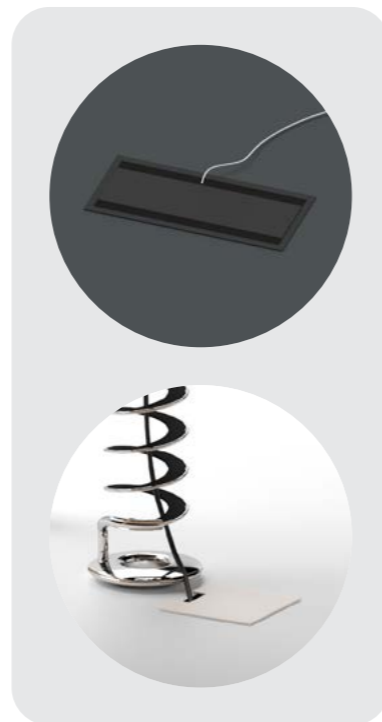
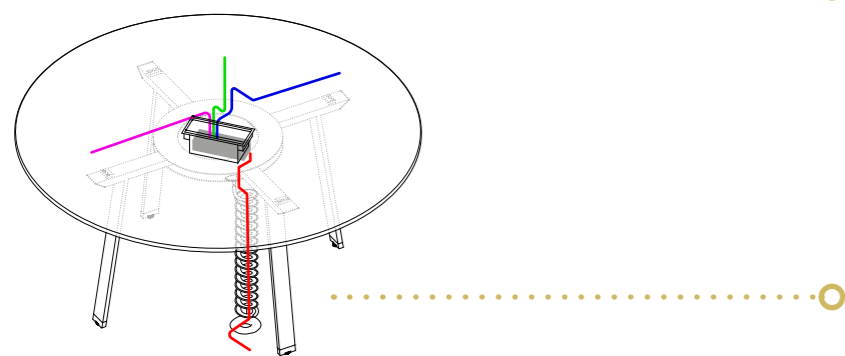
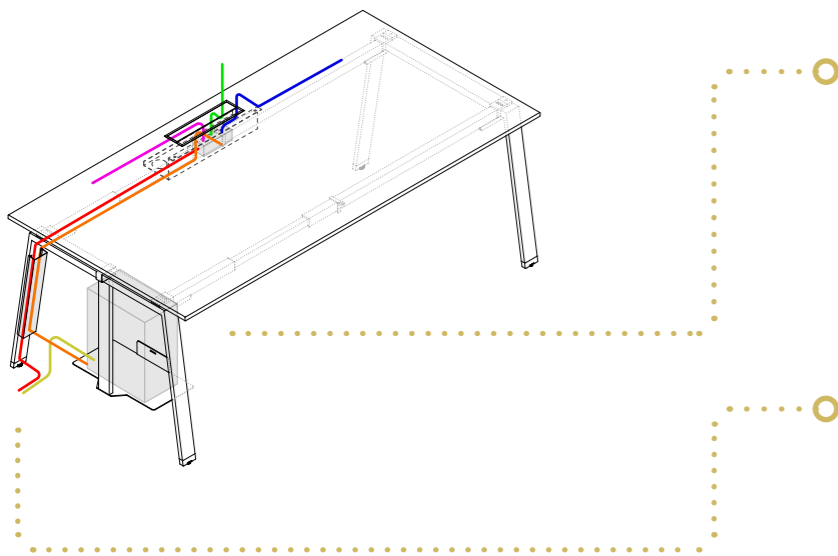

Loopy



Glider



Take-Off

S 1,2 cm: w 100÷120 cm d 60 cm
w 140÷200 cm d 80 cm
w 200 cm d 100 cm

h 74 cm

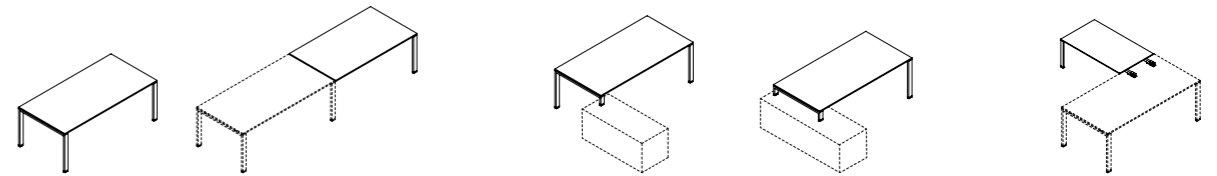

w 80÷200 cm
d 60-80 cm

w 200 cm
d 100 cm

w 160÷200 cm
d 80 cm

w 200 cm
d 100 cm

w 80-120 cm
d 60 cm

s 1,2-1,6-1,8-1,9 cm

h 2 cm

h 30 cm

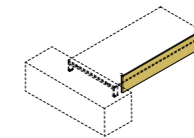
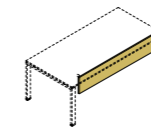
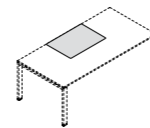

w 70 cm
d 50 cm

w 118,5-138,5-158,5 cm
d 1,8 cm

w 98,5-118,5-138,5 cm
d 1,8 cm

h 54 cm

h 54 cm

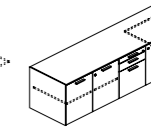
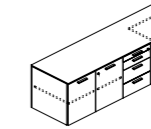
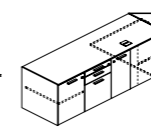
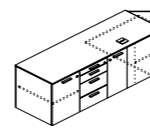

w 167,2 cm
d 56,2 cm

w 208,9 cm
d 56,2 cm

h 58,7 cm

h 54 cm

h 54 cm

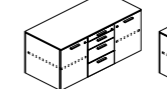
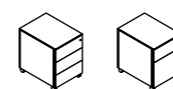

w 32-42 cm
d 56,2 cm

w 83,6 cm
d 56,2 cm

w 125,3 cm
d 56,2 cm



 Loopy  Glider  Take-Off

h 73,7 cm

h 124,9 cm

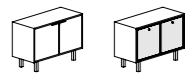

w 102,4 cm
d 46 cm

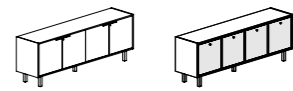

w 202,4 cm
d 46 cm

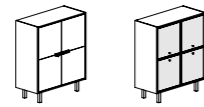

w 102,4 cm
d 46 cm

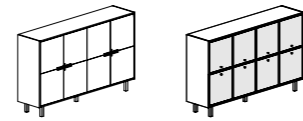

w 202,4 cm
d 46 cm

h 74 cm

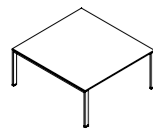

w 100÷240 cm
d 124-164 cm

s 1,8 cm

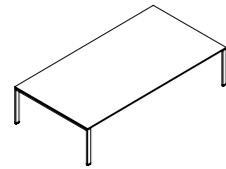

w 240 cm
d 124 cm

s 1,2 cm

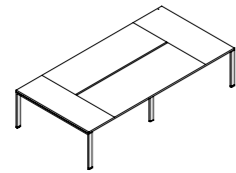

w 280-320 cm
d 124-164 cm

s 1,8 cm

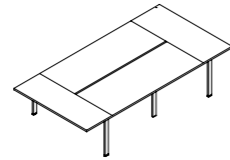

w 240-320 cm
d 124-164 cm

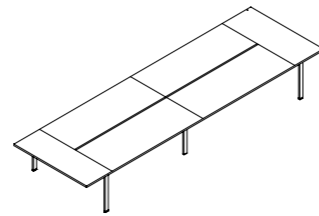

w 360-520 cm
d 124-164 cm



h 74 cm

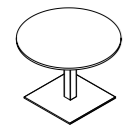

ø 110-118 cm

s 1,8 cm

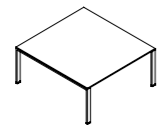



w 124 cm
d 124 cm

s 1,2 cm

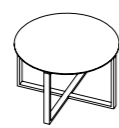

h 74 cm





ø 118 cm 

s 1,2-1,8 cm

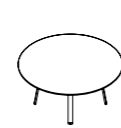

h 74 cm





ø 118 cm 

s 1,2-1,8 cm

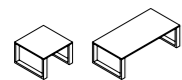

h 38 cm



w 60-120 cm
d 60 cm 

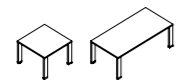

w 60-120 cm
d 60 cm 

h 42 cm





plastica, plastic, plastique,
Plastik, plàstic

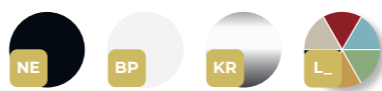

metallo, metal, métal,
metall, metal



plastica, plastic, plastique,
Plastik, plàstic



metallo, metal, métal,
metall, metal



plastica, plastic, plastique,
Plastik, plàstic



metallo, metal, métal,
metall, metal





selezione delle materie prime • selection of raw materials • sélection des matières premières • Auswahl der Rohstoffe • seleccion de materias primas

attenzione e cura nella scelta dei materiali: Legno impiallacciato / vetro / pelle / tessuto / vetro ceramica • attention and care in the selection of materials: veneer / glass / leather / fabric / vitro ceramic • attention et soin dans la sélection des matériaux: bois plaquage/verre/peau/tissu/vitro-céramique • Aufmerksamkeit und Sorgfalt bei der Auswahl der Materialien: Holz furnier / Glas / Leder / Stoff / Glaskeramik • atención y cuidado en la selección de los materiales: madera pintada/vidrio/piel/tejido/vidrio ceramica



produzione certificata, ecologica e rispettosa dell'ambiente e dell'utente • certified production, green environmentally and user friendly • production certifiée, écologique et respectueuse de l'environnement et de l'individu • Zertifizierte, umweltfreundliche Produktion mit großer Respekt für Umwelt und Nutzer • Produccion certificada, ecologica y respetuosa del ambiente y del usuario

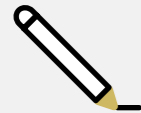

progettazione • space planning • projets • Projekte • proyectos



capacità di produzione industriale • industrial production ability • capacité de production industrielle • industrielle Produktionskapazität • capacidad de producción industrial



garanzia e disponibilità dei componenti • warranty and availability of components • garantie et disponibilité des composants • Garantie und Verfügbarkeit der Komponenten • garantía y disponibilidad de los componentes



esperienza • experience • expérience • Erfahrung • experiencia



articoli speciali • special items • articles spéciaux • Sonderanfertigungen • artículos especiales

il nostro sistema di produzione segue standard avanzati per la cura dell'individuo e della natura • our production system follows advanced standards for individual and nature care • notre système de production suit des standards avancées pour le soin de l'individu et de la nature • Unser Produktionsverfahren fortschrittlichen Standards für den Schutz von Mensch und Natur • nuestro sistema de producción sigue estandar avanzados para el cuidado al individuo y a la naturaleza



I nostri prodotti in melaminico possono essere certificati FSC® su richiesta cliente. Our melamine products can be FSC® certified upon customer request. Nos produits en mélaminé peuvent être fournis certifiés FSC® sur demande du client. Unsere Melamin-Produkte können auf Anfrage des Kunden in FSC® zertifiziert werden. Nuestros productos de melamina pueden tener la certificación FSC® a petición del cliente.

The mark of responsible forestry

la nostra azienda opera con l'obiettivo primario di garantire prodotti che raggiungano un corretto equilibrio tra sostenibilità ambientale e design • our Company operates with the primary objective of guaranteeing products that achieve a correct balance between, environmental sustainability and design • notre société a comme objectif principal celui de garantir des produits qui atteignent un juste équilibre entre, durabilité environnementale et design • Unsere Firma hat sich als Hauptziel die Garantie von Produkten gesetzt, welche ein korrektes Gleichgewicht zwischen Umweltverträglichkeit und Design erzielen • nuestra empresa trabaja con el objetivo primario de garantizar productos que alcanzan un correcto equilibrio entre sostenibilidad ambiental y de diseño



imballi costituiti da materiali facilmente separabili e riciclabili • recyclable and easy to dispose packagings • emballages constitués de matériaux facilement séparables et recyclables • Die Verpackungen ermöglichen ein schnelles Trennen und Wiederverwertung von Materialien • embalaje constituido de materiales simplemente separables y reciclables



TSCA Title VI Compliant

riduzione di formaldeide e di sostanze tossiche e potenzialmente dannose • low formaldehyde emission, low toxic and potentially harmful substances • réduction de formaldéhyde et des substances toxiques et potentiellement nocives • Reduzierung von Formaldehyd und Giftstoffe, die eine potentielle Gefahr darstellen • reducción de formaldehido y sustancias tóxicas y que pueden ser dañinas



estensione del ciclo di vita dei prodotti • product life extension • extension du cycle de vie du produit • Erweiterung der Produktlebensdauer • extension del ciclo de vida de los productos



produzione di arredi a ridotto impatto ambientale • furniture products with reduced environmental impact • production de mobiliers à impact environnemental réduit • Produktion von Einrichtungen mit niedriger Umweltbelastung • producción de mobiliario con reducido impacto ambiental



facilità di disassemblaggio per favorire la riconfigurabilità, il riutilizzo o il riciclo • easy reconfiguration, reuse or recycling • simplicité de démontage pour favoriser la reconfiguration, la réutilisation ou le recyclage • Leichte Zerlegung um Rekonfigurierbarkeit, Wiederverwendung oder Recycling zu ermöglichen • facilidad de desensamblaje para facilitar el configurar de nuevo, reutilizar y reciclar

Edizione Marzo 2022 - Particolari tecnici ed estetici possono essere modificati senza preavviso. Le rese cromatiche non sono vincolanti così come la fedeltà della riproduzione. Dati, misure e dettagli devono essere verificati con il listino.

March 2022 Edition - Technical and aesthetic details can be modified without notice. Colour rendering may differ. Check the data, measures and details on the price list.

Édition mars 2022 - Les détails techniques et esthétiques peuvent être modifiés sans préavis. Le rendu chromatique n'est pas contractuel, ainsi que la fidélité de la reproduction. Les données, les mesures et les détails doivent être vérifiés avec le tarif.

Ausgabe März 2022 - Technische und ästhetische Details könnten ohne Vorankündigung geändert werden. Die Echtheit der Farbwiedergabe ist nicht verbindlich. Daten, Maße und Details sind in der Preisliste zu überprüfen.

Edición marzo 2022 - Los detalles técnicos y estéticos pueden ser modificados sin preaviso. Los rendimientos de color y la fidelidad de la reproducción no son vinculantes. Los datos, las medidas y los detalles deben ser verificados con la tarifa.

 **bralco**

MBS

Aménageur d'Espaces...

www.mbs95.com

15, rue de la Briqueterie 95330 DOMONT
Tél. 01 39 35 41 80 Fax 01 39 35 41 76 commercial@mbs95.com



